



# Parts List

## ULTRA HIGH SPEED BURNISHER DR1500H



english	User Manual.....	1-9
deutsch	Betriebsanleitung.....	xxx
français	Notice d'utilisation .....	xxx
nederlands	Gebruiksaanwijzing.....	xxx
italiano	Istruzioni sull'uso.....	xxx
español	Instrucciones de manejo.....	xxx
português	Instruções de operação.....	xxx

### Company information:

[www.vipercleaning.eu](http://www.vipercleaning.eu)

[enfo-eo@vipercleaning.com](mailto:enfo-eo@vipercleaning.com)

xxxxx (1) – 2009-01-01



**DESCRIPTION****PLAN**

Parts List	3-6
Wear and Tear Parts List	7

**WHEN ORDERING PARTS**

- \* Use the 7,8 or 9 digit part numbers from the “part number” columns in this parts list.
- \* Specify the model and serial number of the machine.
- \* Use the space below to record the model and the serial Number for future reference.

**Model**\_\_\_\_\_**Serial No.**\_\_\_\_\_

HANDLE GROUP FOR DR1500H

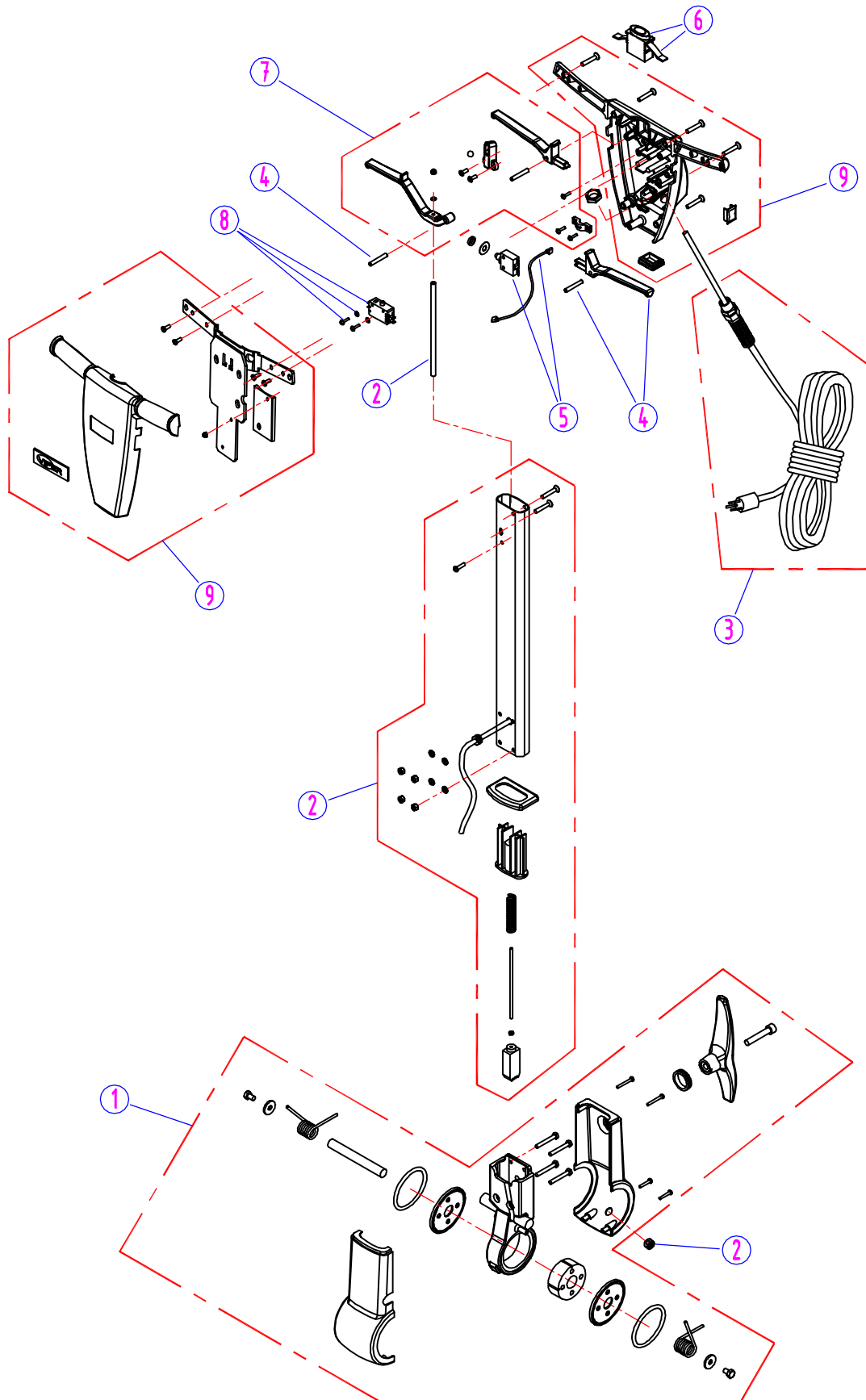

## **HANDLE GROUP FOR DR1500H**

<b>DIA NO</b>	<b>PART NUMBER</b>	<b>DESCRIPTION</b>	<b>NO REQ'D</b>
1	VF52201	GEAR SEAT KIT INCL GEAR	1
2	VF52202	HANDLE TUBE KIT INCL PLUNGER	1
3	VF52203	POWER CORD W/UK PLUG KIT INCL S/R BUSHING	1
	VF52204	POWER CORD W/EU PLUG KIT INCL S/R BUSHING	1
4	VF52205	LEFT SWITCH LEVER KIT INCL PINS	1
5	VF52206	CIRCUIT BREAKER KIT INCL JUMP WIRE	1
6	VF52207	SAFETY LOCK KIT INCL PLATE SPRING	1
7	VF52208	RIGHT SWITCH LEVER KIT INCL ADJUSTING LEVER	1
8	VF52209	SWITCH KIT INCL SCREWS	1
9	VF52210	HANDLE GRIP KIT INCL SCREWS	1



## **BASE GROUP FOR DR1500H**

<b>DIA NO</b>	<b>PART NUMBER</b>	<b>DESCRIPTION</b>	<b>NO REQ'D</b>
1	VF52211	UPPER COVER KIT INCL VIPER LOGO	1
2	VF52212	LOWER COVER KIT INCL PLASTIC STANDS	1
3	VF52213	ARM KIT INCL SCREWS	1
4	VF52214	TRANSPORTATION AXLE KIT INCL CLAMPS	1
5	VF52215	TRANSPORTATION WHEEL KIT INCL SCREWS	1
6	VF52216	FRONT AXLE KIT INCL CLAMPS	1
7	VF52003	FRAME	1
8	VF52217	DRIVING PULLEY SCREW KIT	1
9	VF52009D	DRIVING PULLEY	1
10	VF52218	FRONT WHEEL KIT INCL AXLE CAPS	1
11	VF52219	PAD HOLDER KIT INCL BIG MOUTH	1
12	VF14079	VEE BELT 43 INCHES	1
13	VF52004A	DRIVEN PULLEY	1
14	VF52220	DRIVEN SHAFT KIT INCL BEARINGS	1
15	VF52221	BUMPER KIT INCL SCREWS	1
16	VF52106	MOUNTING PLATE	2
17	VF52222	CAPACITOR CLAMP KIT INCL SCREWS	1
18	YLQ14401	RUNNING CAPACITOR	1
19	VF52223	MOTOR SCREW KIT	1
20	VF99920	MOTOR 220-240V 1500 RPM	1

### Wear & Tear Parts List

Part No.	Desc	QTY	Machine
VF44203	Switch	1	DR1500H
VF45118-K	Power Cord with UK Plug	1	DR1500H
VF45118-NE	Power Cord with EU Plug	1	DR1500H
VF47055	Wheel, Transportation	2	DR1500H
VF52017	Wheel, 5"	2	DR1500H
VA96851	Cap, Axle	2	DR1500H
VF99024D	Pad Holder	1	DR1500H
VF99003A	Big Mouth	1	DR1500H
VF14079	"V" Belt	1	DR1500H
VF52111B	Spring, Left	1	DR1500H
VF52112B	Spring, Right	1	DR1500H